

TYPE A

8 bag capacity
galvanised steel hinged lid
galvanised mild steel straps
reinforced concrete sections

SIMPLE ASSEMBLY

1. Place the two floor slabs firmly level. All parts sit on the top of these.
2. Round bolt heads to the inside.
3. The two hinges go outside on the back, with the rod through the lid and hinges.

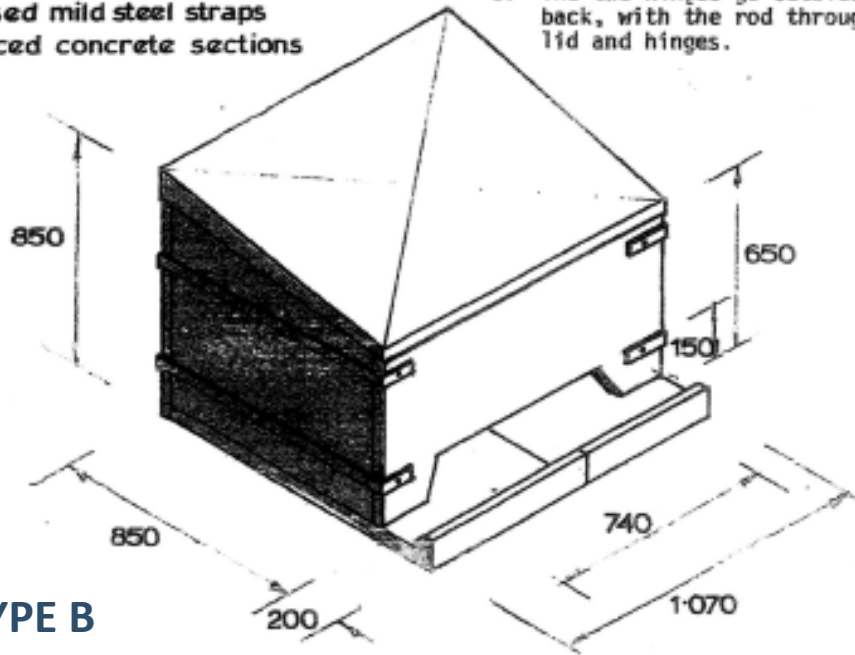

TYPE B



PRECAST CONCRETE

Specialists in fibre reinforced concrete products

Office: (03) 477 2254

Fax: (03) 477 2214

Mobile: 0211 850 580 (Richard Daggar)

Web: www.precastdunedin.co.nz

Street: 78 Maclaggan St, Dunedin 9016

Mailing: PO Box 7093, Dunedin 9040

Coal Box with Lid

Type A: Closed front

Type B: Open front